

2 DRIVEWAY SECTION
SCALE: 1/2" = 1'-0"

LEGEND	SYMBOL
PROPERTY BOUNDARY / RIGHT-OF-WAY	
OVERHEAD POWER	
SEWER PIPE	
STORM DRAIN PIPE	
DITCH	
EXISTING CONTOUR	48.0
EXISTING ELEVATION	47.50
PIPE INVERT ELEVATION	49.07
CONCRETE	
ASPHALT	
GRAVEL	
PP	POWER POLE
RCP	REINFORCED CONCRETE PIPE
CMP	CORRUGATED METAL PIPE
CPP	CORRUGATED PLASTIC PIPE
IE	INVERT ELEVATION

PRINCIPAL BUILDING COVERAGE

TOTAL LOT AREA - 1/3 AC 16,047 SQFT
 PRINCIPAL BUILDING COVERAGE = LOT AREA x 15%
 PRINCIPAL BUILDING COVERAGE = 16,047 x 15%
 PRINCIPAL BUILDING COVERAGE = 2,407 SQFT
 PRINCIPAL BUILDING COVERAGE MAX RELIEF 20% = 481 SQFT
 MAX. PRINCIPAL BUILDING COVERAGE 2,888 SQFT

NEED 10.7% INCREASE OR 258 SQFT
 EXISTING HOUSE 1,290 SQFT
 PROPOSED ADDITION 1,375 SQFT
 PROPOSED ACCESSORY 610 SQFT
 TOTAL BUILDING COVERAGE 3,275 SQFT

PERMITTED PRINCIPAL BUILDING AREA

TOTAL LOT AREA 1/3 AC 16,047 SQFT
 2,400 + (LOT AREA - 5,000) / 100) X 10
 2,400 + (16,047 - 5000) / 100) X 10
 2,400 + (11,047/100) X 10
 2,400 + 110.47 X 10
 2,400 + 1,105
 3,505 SQFT MAX AREA
 MAX RELIEF - 25% = 876 SQFT
 MAX PRINCIPAL BUILDING AREA 4,381 SQFT

3,530 SQFT HEATED
 INCREASE REQUIRED FOR 25 SQFT OR 0.7%

LOT COVERAGE

TOTAL LOT AREA 16,047 SQFT
 ALLOWABLE COVERAGE @30% 4,814 SQFT
 EXISTING HOUSE 1,290 SQFT
 PROPOSED ADDITION 1,375 SQFT
 EXISTING CISTERN 231 SQFT
 EXISTING PORCHES 264 SQFT
 PROPOSED PORCHES 494 SQFT
 PROPOSED STAIRS 26 SQFT
 EXISTING WALKWAY 138 SQFT
 PROPOSED POOL 368 SQFT
 PROPOSED POOL DECK 880 SQFT
 TOTAL COVERAGE 4,789 SQFT
 TOTAL COVERAGE % 29.8%
 PROPOSED ACCESSORY 610 SQFT

NATURAL VEGETATION RATIO:

TOTAL LOT AREA = 16,047 SQFT
 TOTAL COVERAGE (STRUCTURE, POOL, CISTERN ETC) = 4,925 SQFT
 PERCENTAGE OF NATURAL VEGETATION = 69.3%

Station 18

HARDSCAPE HOLD HARMLESS AGREEMENT

AUTHORIZATION OF THIS WORK IN THE SCDOT RIGHT-OF-WAY IN NO WAY IMPLIES THE ADJACENT PROPERTY OWNER(S) ABILITY TO OBSTRUCT PUBLIC PARKING; OR, INSTALL SIGNAGE TO OBSTRUCT OR PROHIBIT PARKING; OR RELOCATE EXISTING DRIVEWAYS / ACCESS WITHOUT PRIOR BUILDING DEPARTMENT APPROVAL; OR, PROHIBIT GENERAL PUBLIC USE OF THIS NEWLY ESTABLISHED SURFACE. A SIGNED WAIVER MUST BE HELD BY THE TOWN WITH THIS PERMIT TO ESTABLISH THAT SHOULD THE PAVERS BE REMOVED THE TOWN IN IN NO WAY RESPONSIBLE FOR REPLACEMENT OF THE HARDSCAPE SYSTEM

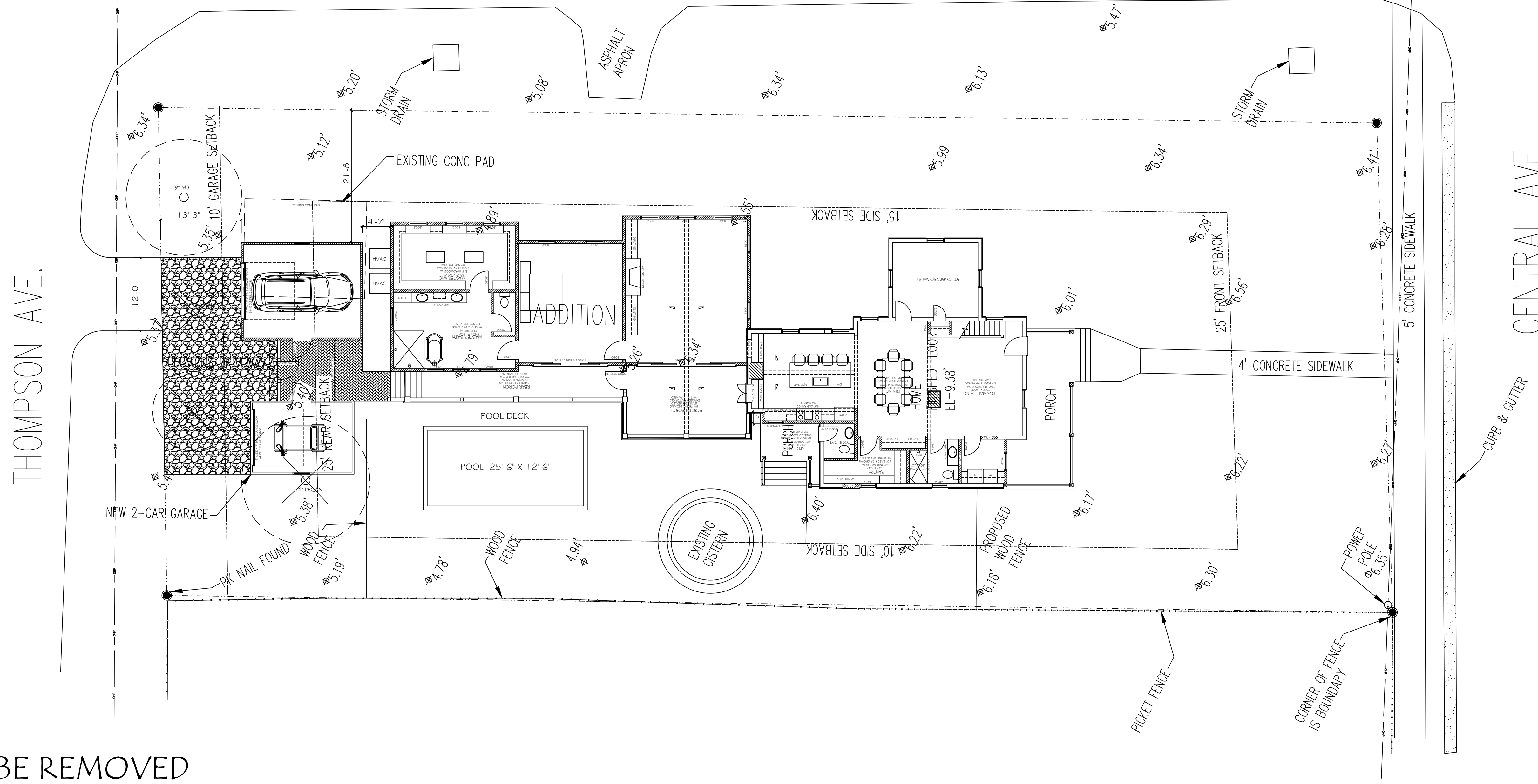

TREE TO BE REMOVED

1 PROPOSED SITE PLAN
SCALE: 1" = 10'-0"

ISSUED FOR CONSTRUCTION

OWNERS SIGNATURE: _____

CONTRACTORS SIGNATURE: _____

DATE: _____

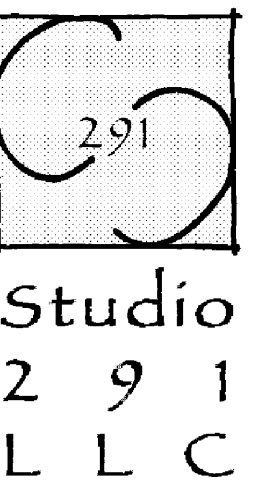

295 Seven Farms Drive
 Suite G-174
 Charleston, South Carolina 29492
 P. (843) 819-8947

This drawing and the design shown is the property of Studio 291, LLC. The reproduction, copying or other use of this drawing without the written consent is prohibited and any infringement will be subject to legal action.

© 2023
 Studio 291, LLC

Project
 Addition & Renovation @
 1754 Central Ave., Sullivan's Island, South Carolina

Sheet Title
 PROPOSED SITE PLAN

D. P. in Charge
 J. ADRIAN
 Job Captain
 J. ADRIAN
 Drawn By
 JAA
 Date Drawn
 6/3/23
 Issued for Pricing
 X
 Issued for Permit
 XXX

Revisions
 No. _____ Date _____
 No. _____ Date _____
 No. _____ Date _____
 No. _____ Date _____
 No. _____ Date _____
 No. _____ Date _____

Issue Date XXX

Project Number
 22-291-888

Sheet 3 of 19
 C2

LIGHTING / ELECTRICAL LEGEND:

	2' OR 4' SINGLE TUBE FLUORESCENT FIXTURE		DUPLEX OUTLET		SINGLE PHASE SWITCH
	8' SINGLE TUBE FLUORESCENT FIXTURE		GROUNDING DUPLEX OUTLET		THREE WAY SWITCH
	5' RECESSED INCANDESCENT DOWNLIGHTING		FLOOR OUTLET - OWNER TO LOCATE		DIMMER SWITCH
	WALL MOUNTED FIXTURE		WEATHER PROOF OUTLET		SMOKE DETECTOR
	CEILING MOUNTED FIXTURE		MOTION SENSOR FLOOD	ALL OUTLETS SHALL BE MOUNTED IN THE BASE BOARD	
	WALL SCONCE / GAS LIGHT		MULTI-MEDIA LOCATION (CABLE, SATELLITE, PHONE & DATA)		
	CEILING MOUNTED FAN		TV, CABLE LOCATION		
	PENDANT / CEILING MOUNTED FIXTURE		PHONE OUTLET		
	EXHAUST VENT - 100 CFM MIN.		DATA JACK		
	SMALL PENDANT				

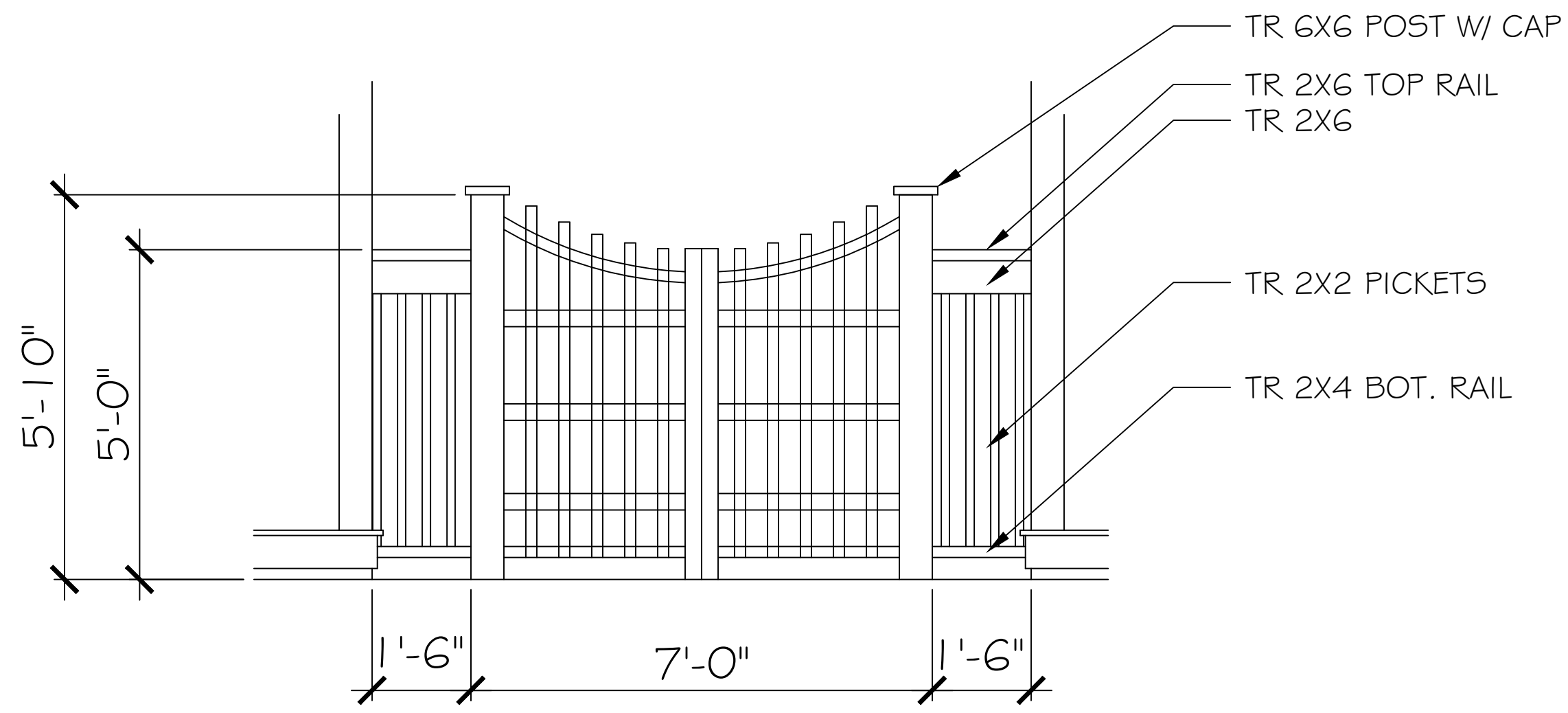

3 DETAIL @ WOOD GATE
SCALE: 1/2" = 1'-0"

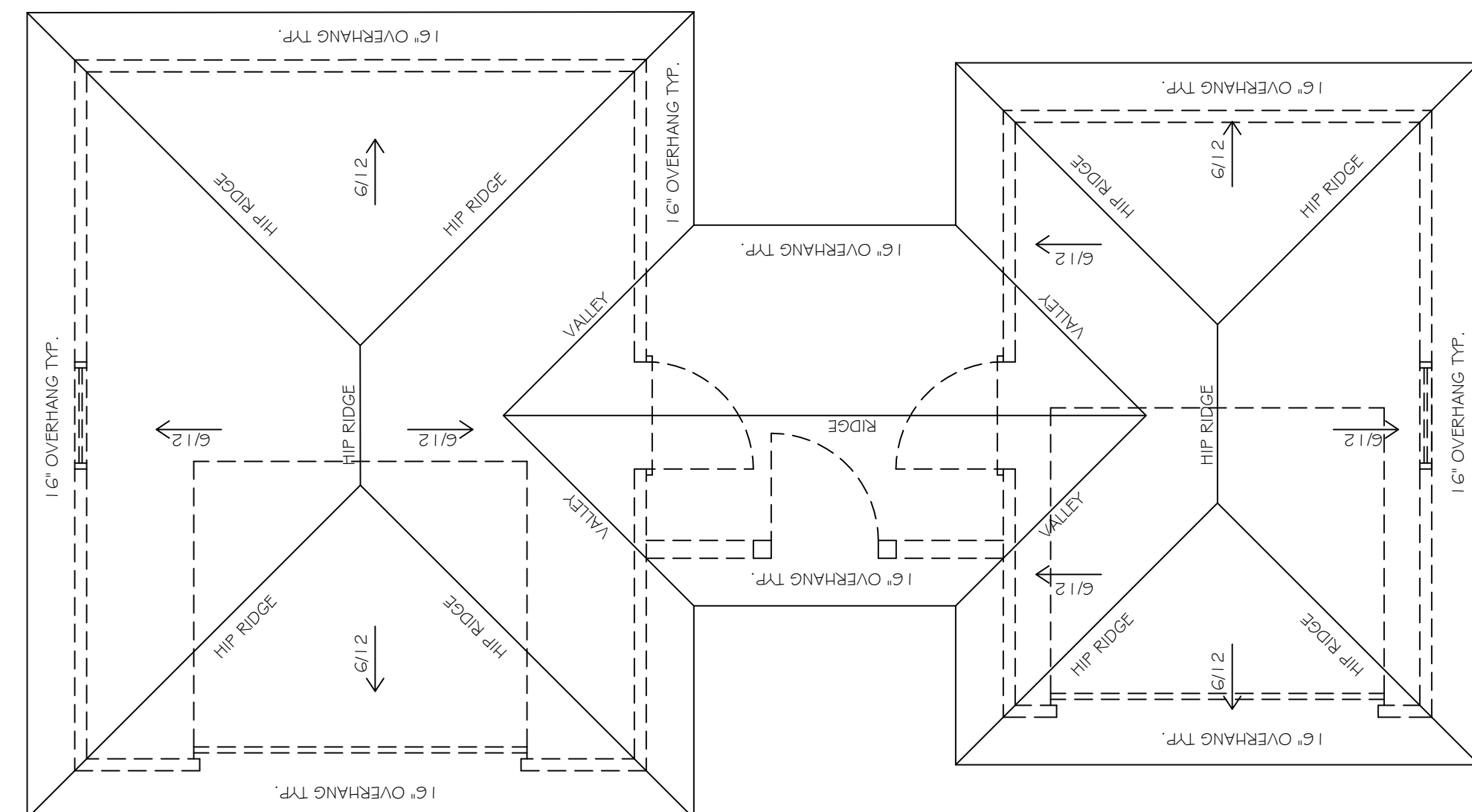

2 GARAGE ROOF PLAN
SCALE: 1/4" = 1'-0"

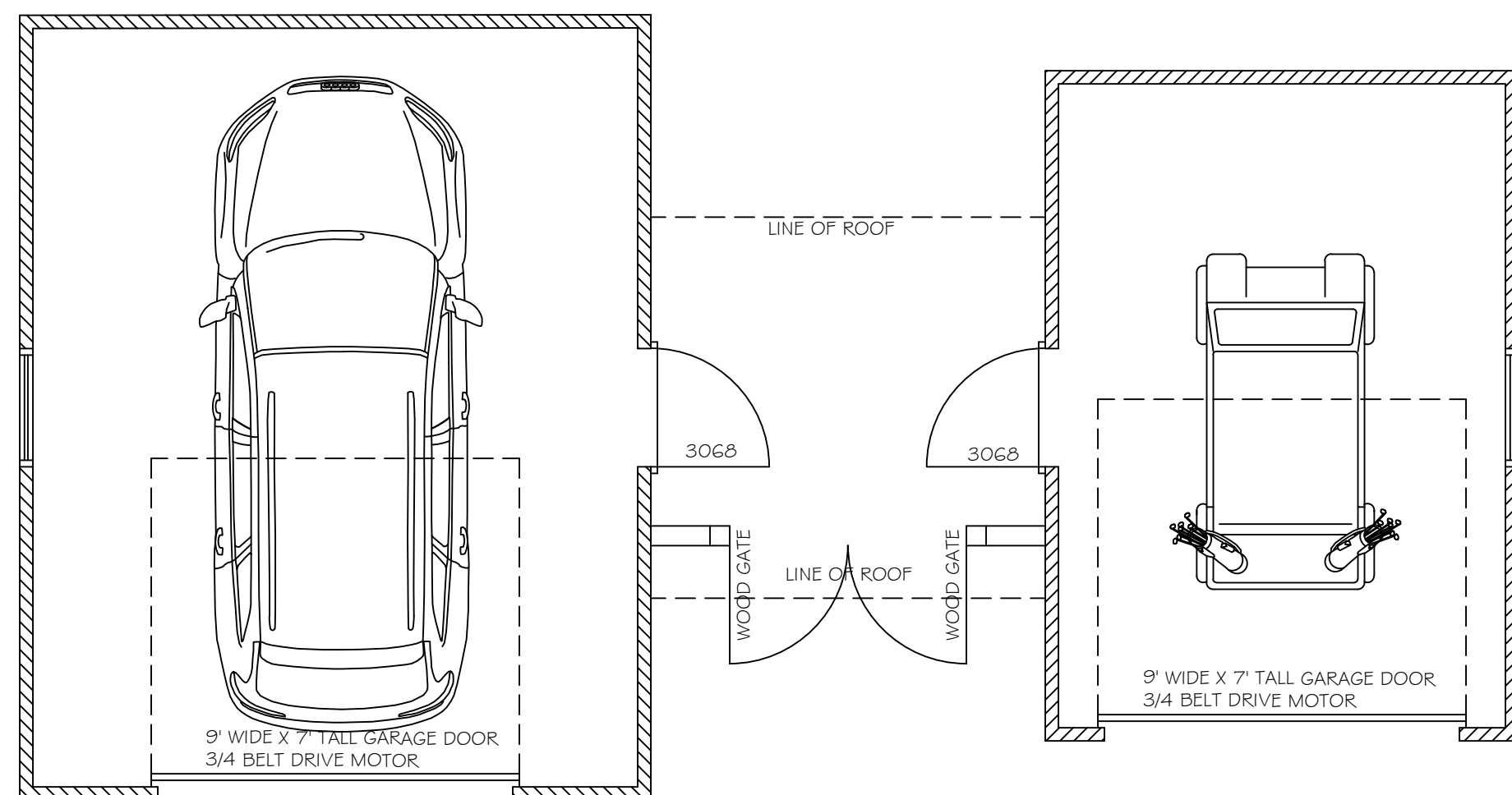

1 GARAGE PLAN - 620 SQFT UNDER ROOF
SCALE: 1/4" = 1'-0"

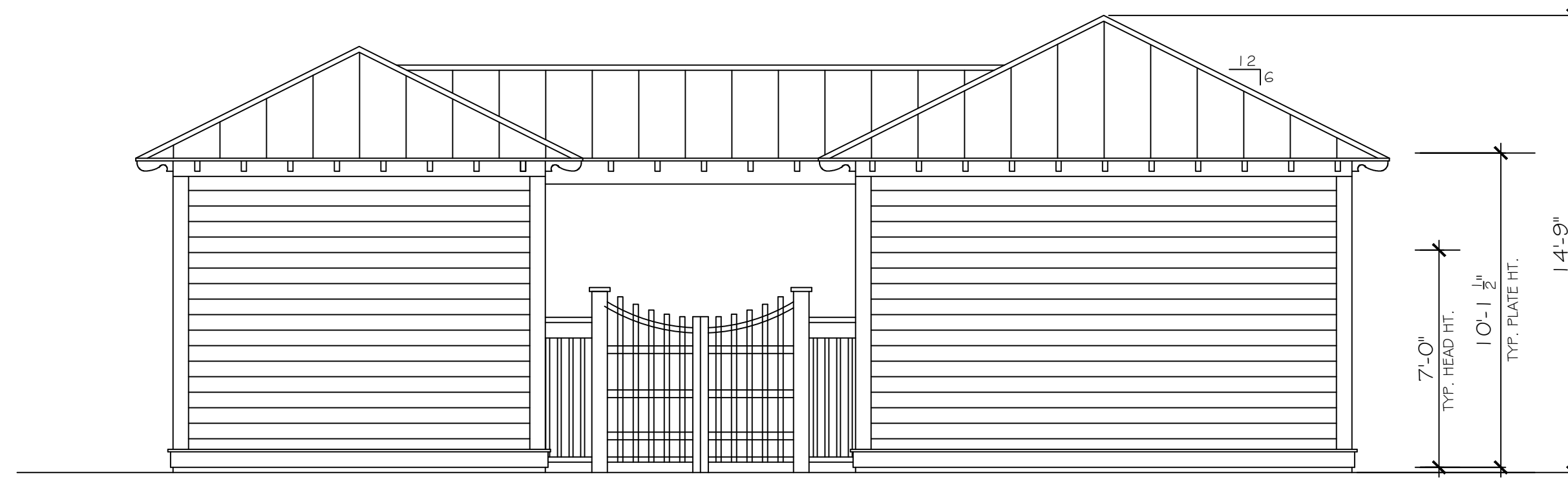

6 REAR ELEVATION
SCALE: 1/4" = 1'-0"

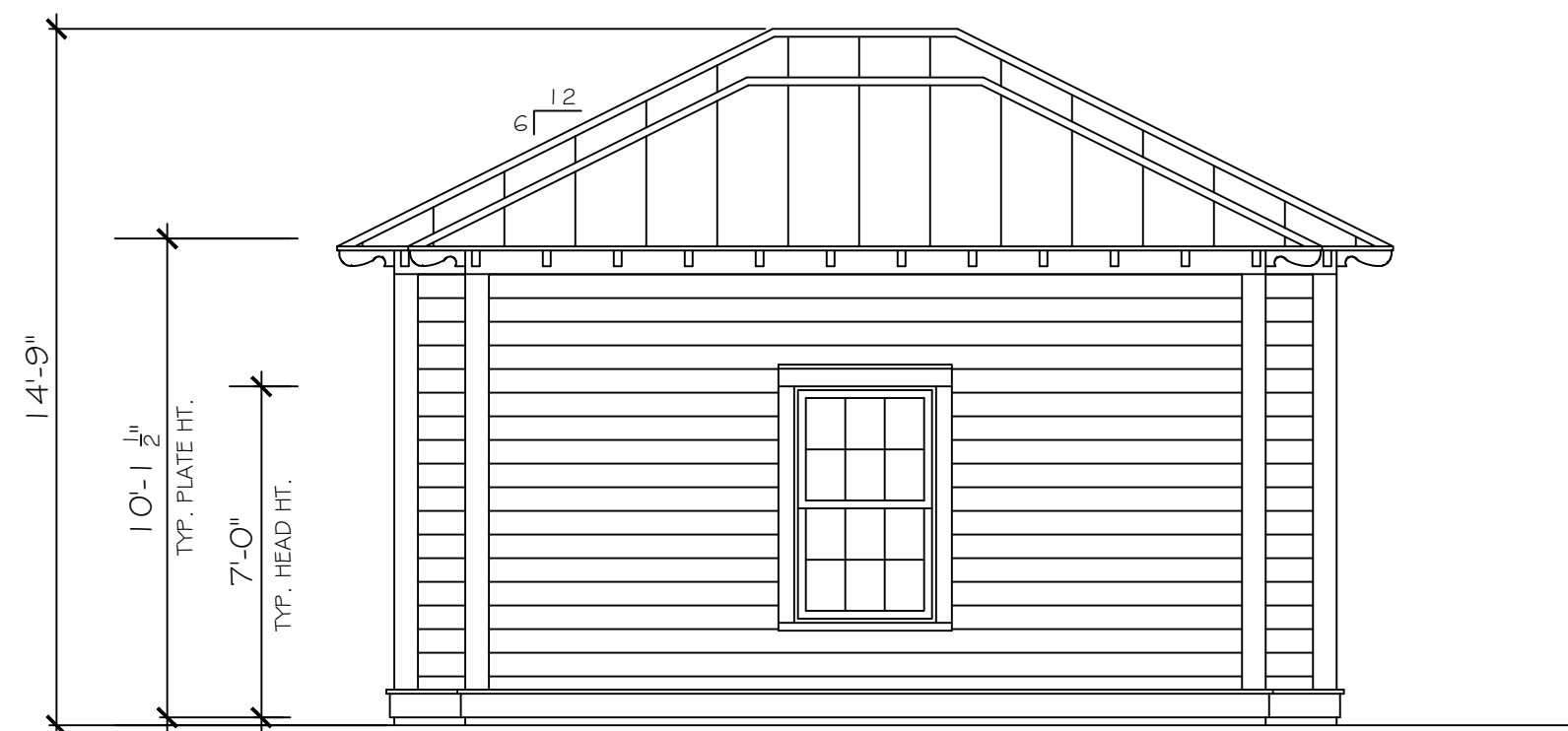

5 RIGHT SIDE ELEVATION
SCALE: 1/4" = 1'-0"

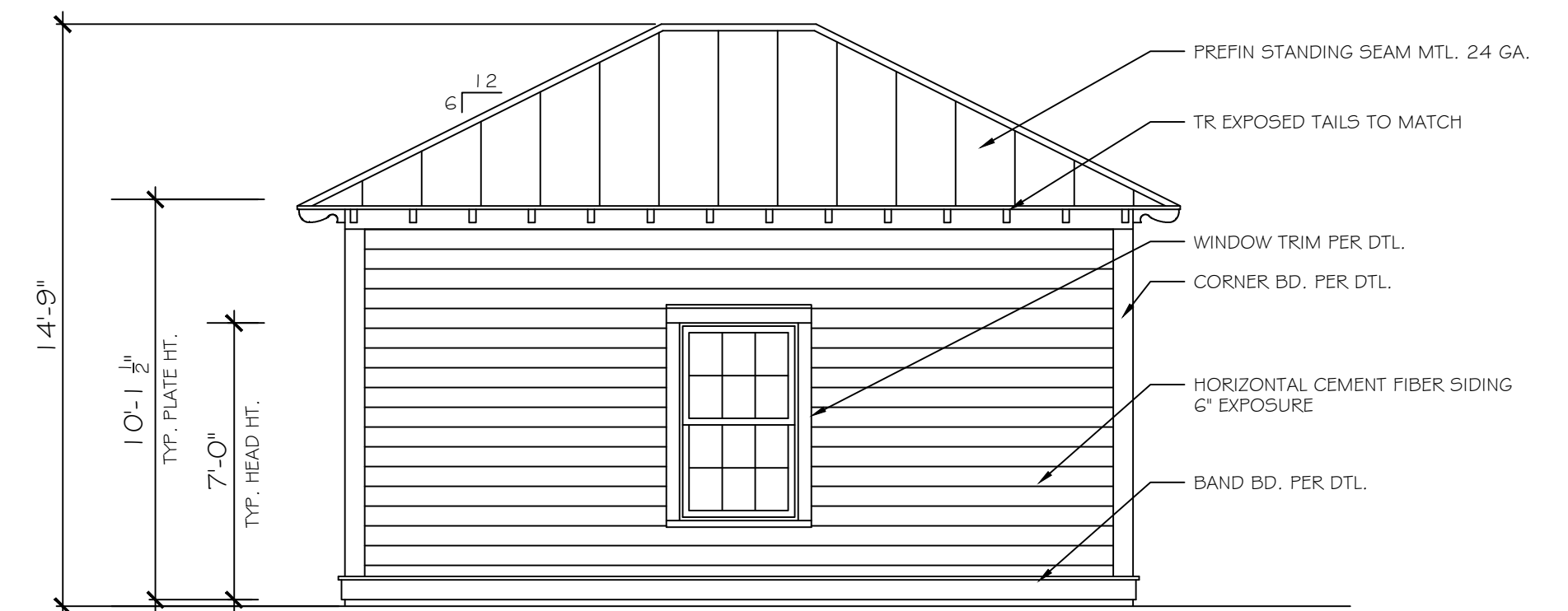

7 LEFT SIDE ELEVATION - STATION 18
SCALE: 1/4" = 1'-0"

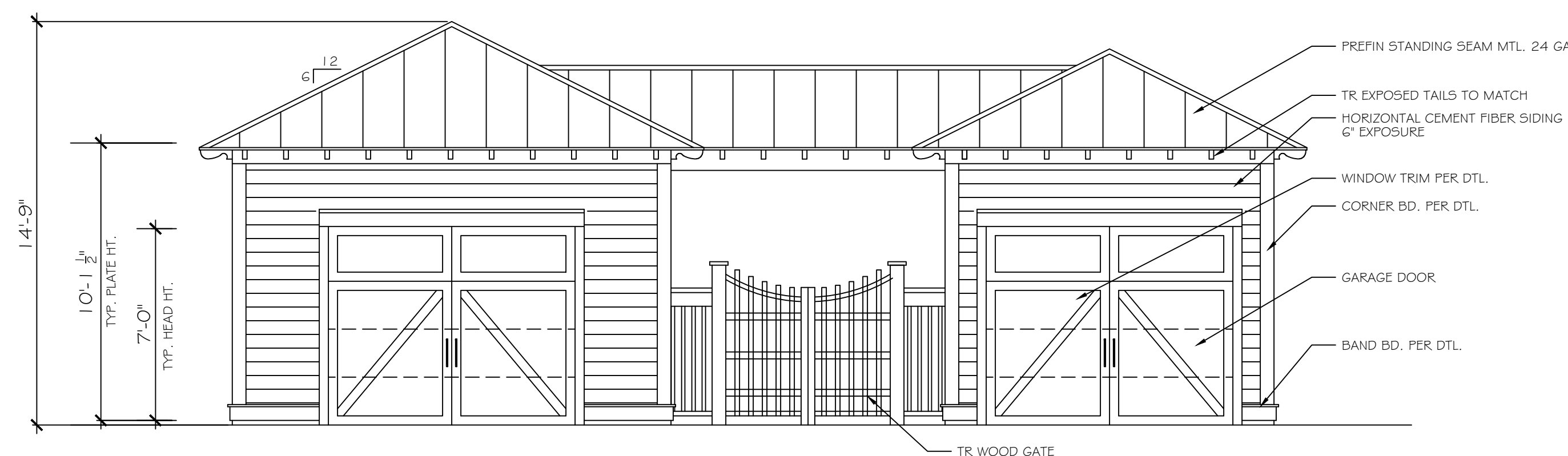

4 FRONT ELEVATION - THOMPSON AVE.
SCALE: 1/4" = 1'-0"

ISSUED FOR CONSTRUCTION

OWNERS SIGNATURE: _____
CONTRACTORS SIGNATURE: _____
DATE: _____

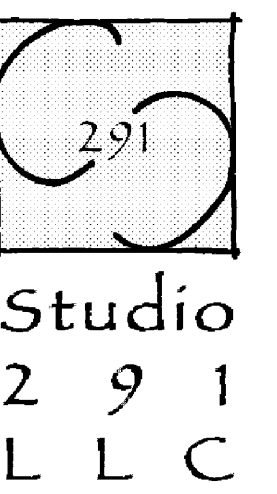

295 Seven Farms Drive
Suite G-174
Charleston, South Carolina 29492
P. (843) 819-8947

This drawing and the design shown is the property of Studio 291, LLC. The reproduction, copying or other use of this drawing without the written consent is prohibited and any infringement will be subject to legal action.
© 2022
Studio 291, LLC

620 SQFT UNDER ROOF

Project: Addition & Renovation @ 1754 Central Ave., Sullivan's Island South Carolina
Sheet Title: DETACHED GARAGE PLANS & ELEVATIONS

D. P. in Charge	_____
J. ADRIAN	_____
Job Captain	_____
J. ADRIAN	_____
Drawn By	_____
JAA	_____
Date Drawn	6/3/23
Issued for Pricing	X
Issued for Permit	8/26/22
Revisions	
No. _____	Date _____
No. _____	Date _____
No. _____	Date _____
No. _____	Date _____
No. _____	Date _____
No. _____	Date _____
Issue Date	8/26/22

Project Number: 22-291-888
Sheet 12 of 19
A1

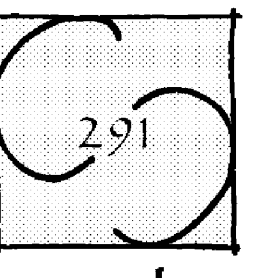

Studio
291
LLC

295 Seven Farms Drive
Suite G-174
Charleston, South Carolina 29492
P. (843) 819-8947

This drawing and the design shown
is the property of Studio 291, LLC.
The reproduction, copying or other
use of this drawing without the
written consent is prohibited and
any infringement will be subject to
legal action.

© 2023
Studio 291, LLC



3 PROPOSED REAR ELEVATION
A2



4 PROPOSED FRONT ELEVATION
A2

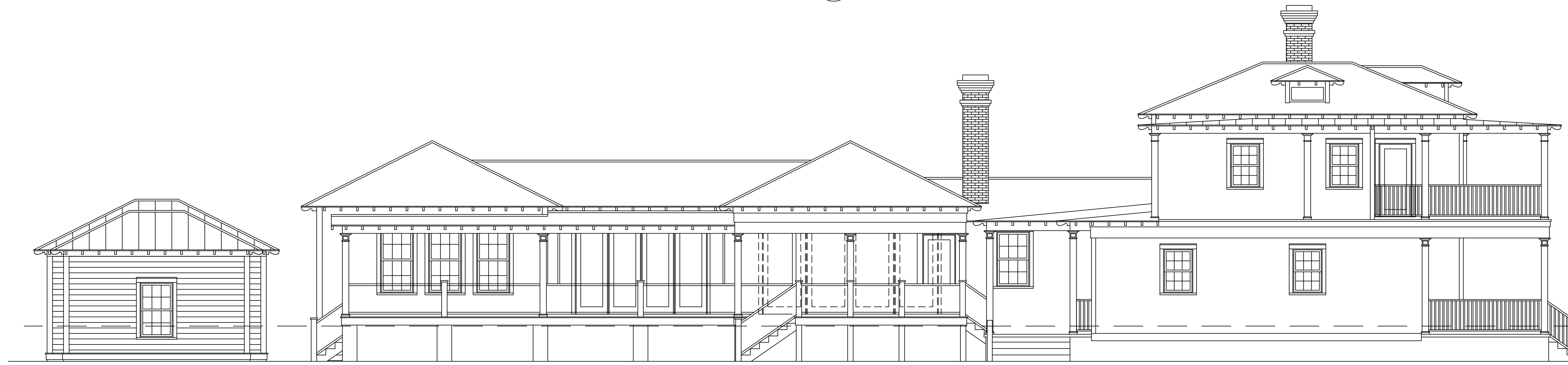

2 PROPOSED LEFT SIDE ELEVATION
A2



1 PROPOSED RIGHT SIDE ELEVATION - STATION 18
A2

Project
Addition & Renovation @
1754 Central Ave., Sullivan's Island South Carolina
Sheet Title
PROPOSED GARAGE ELEVATIONS W/ HOUSE

D. P. in Charge
J. ADRIAN
Job Captain
J. ADRIAN
Drawn By
JAA
Date Drawn
6/3/23
Issued for Pricing
X
Issued for Permit
XXXX

Revisions
No. Date
No. Date
No. Date
No. Date
No. Date
No. Date

Issue Date XXXX

Project Number
22-291-888

Sheet 9 of 19
A2

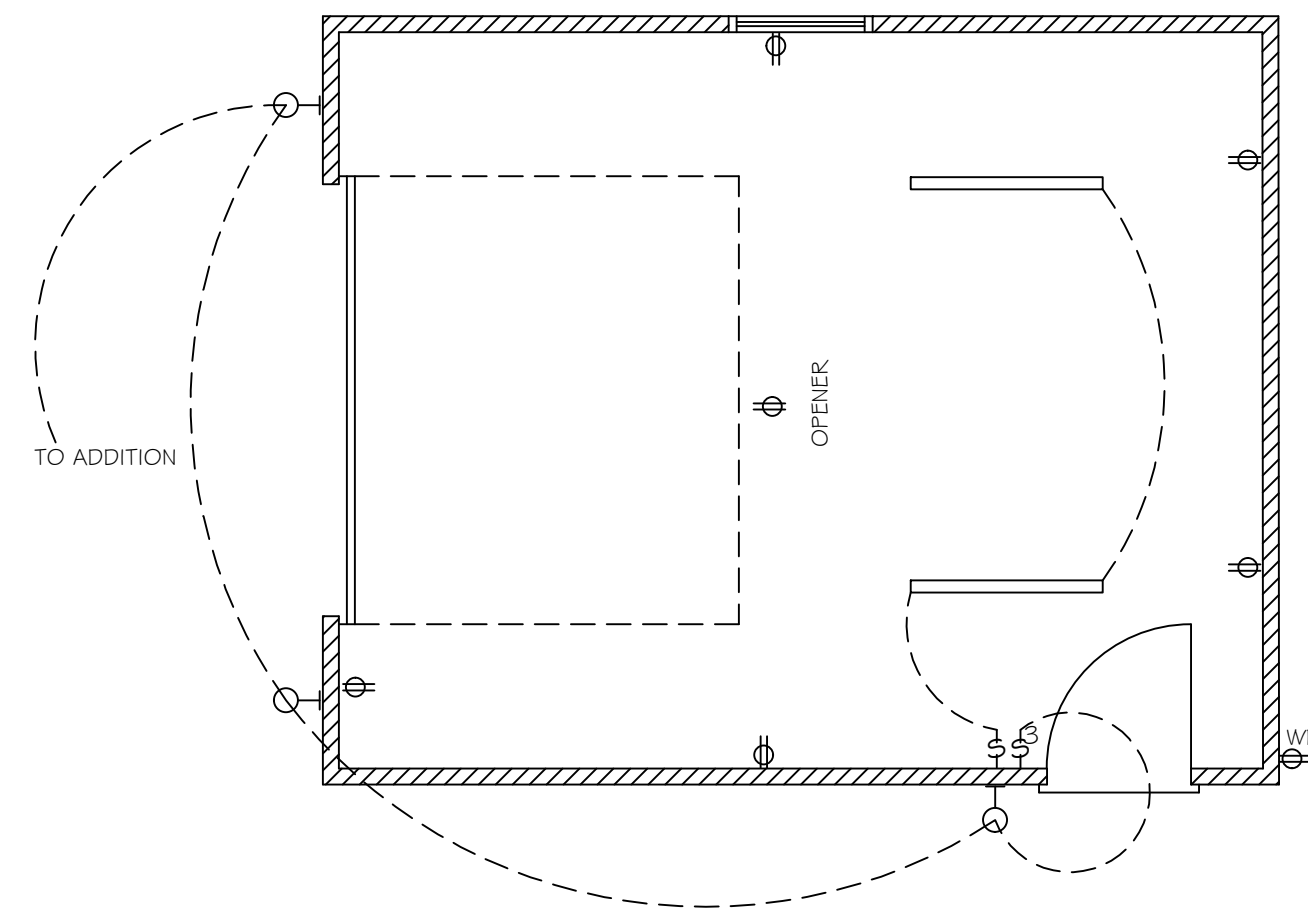

7 GARAGE ELECTRICAL PLAN
SCALE: 1/4" = 1'-0"

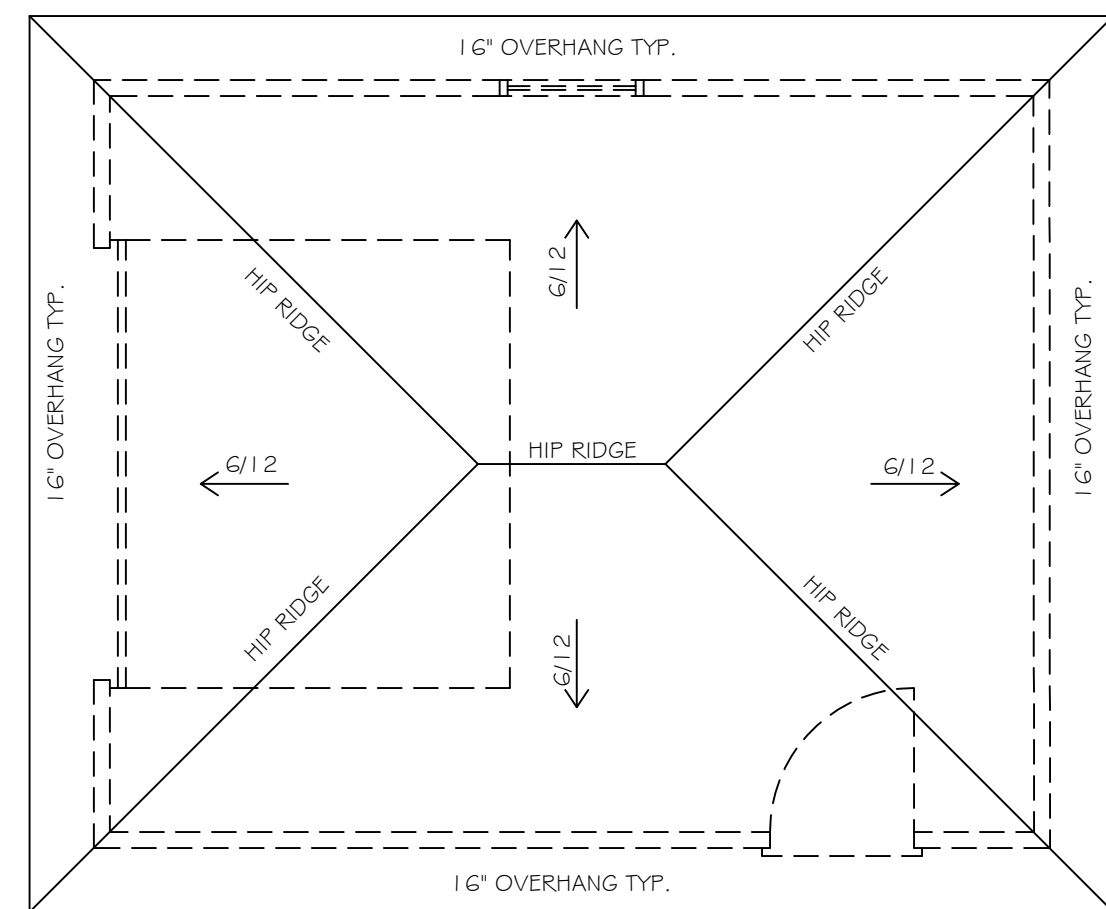

4 GARAGE ROOF PLAN
SCALE: 1/4" = 1'-0"

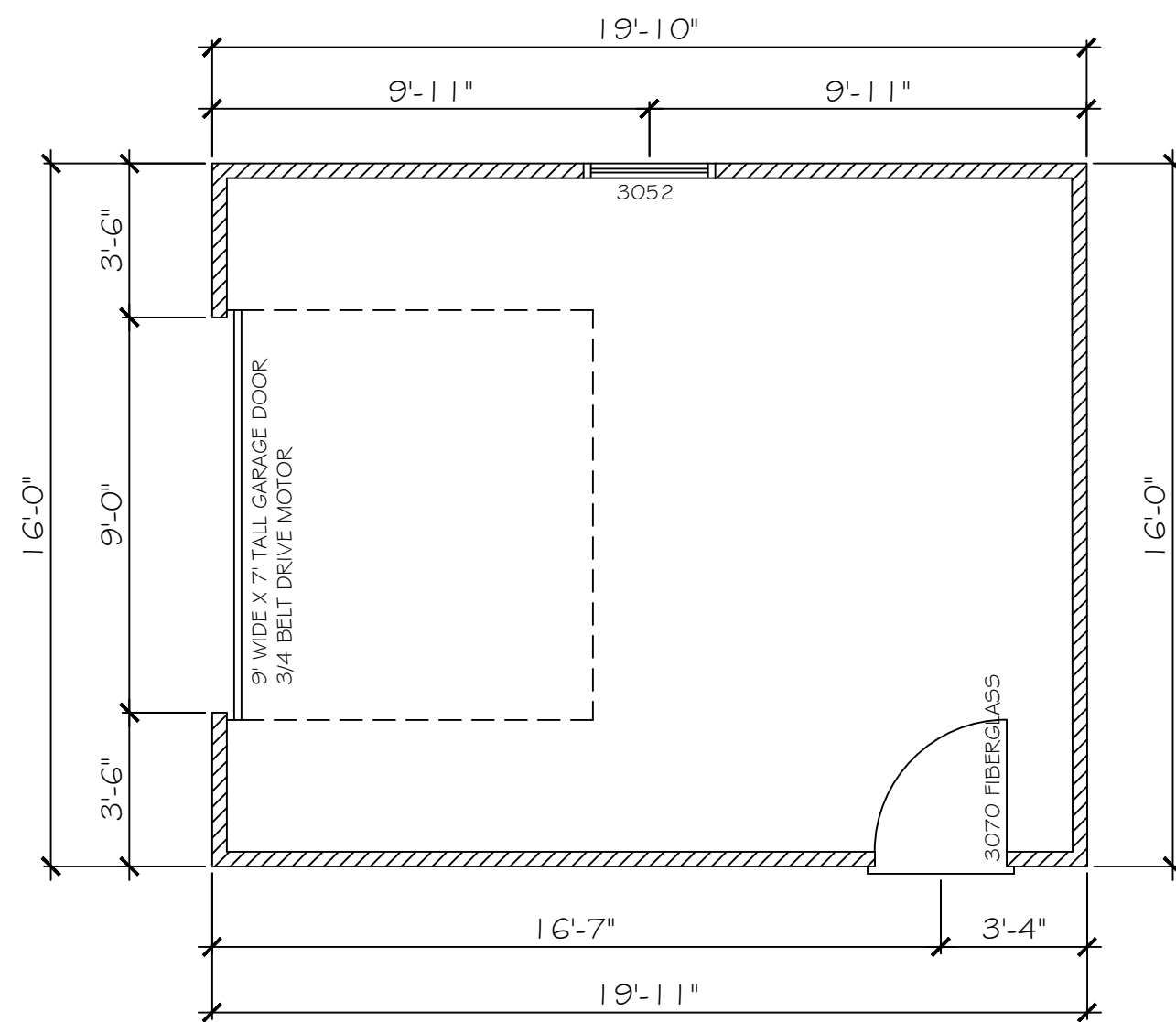

1 GARAGE PLAN
SCALE: 1/4" = 1'-0"

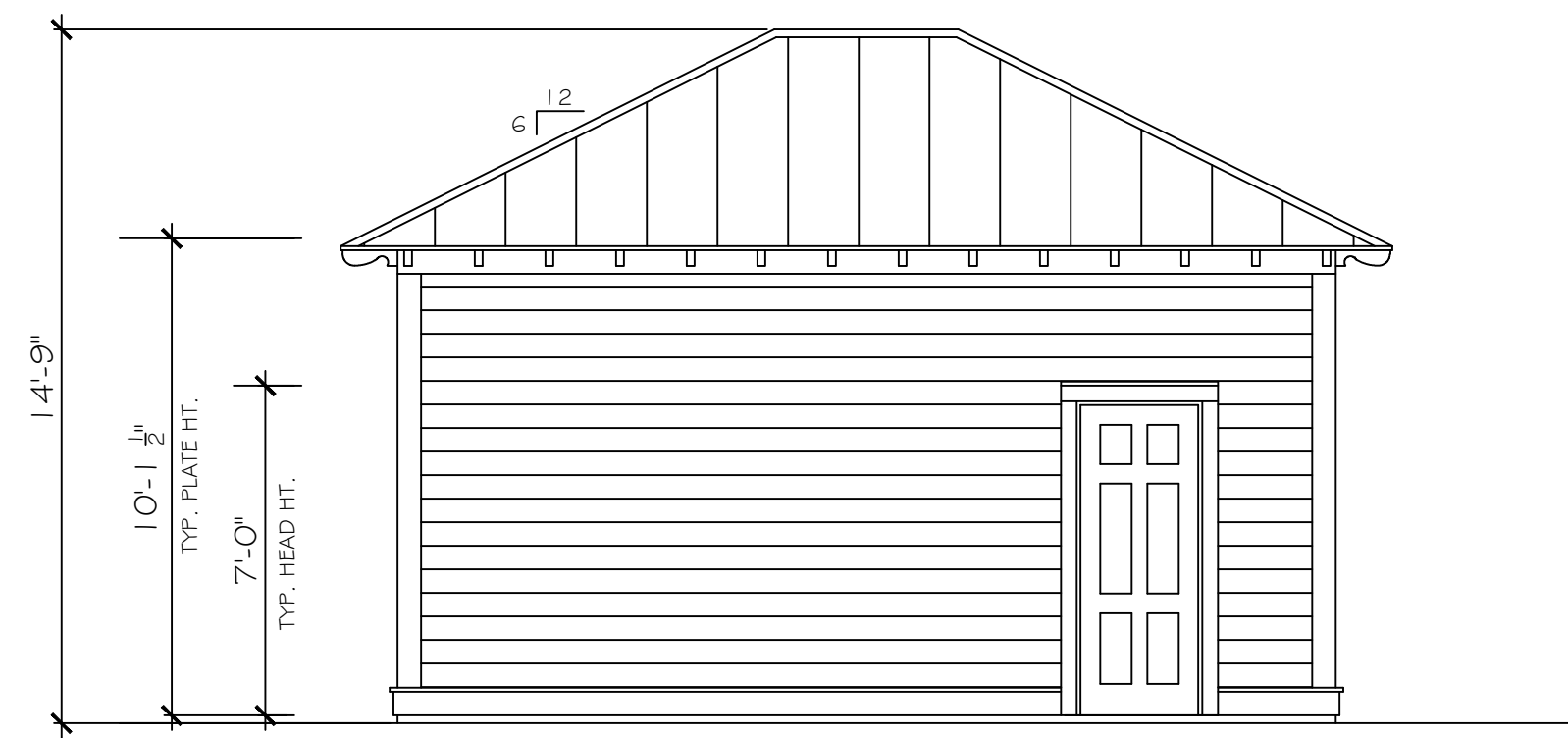

5 RIGHT SIDE ELEVATION
SCALE: 1/4" = 1'-0"

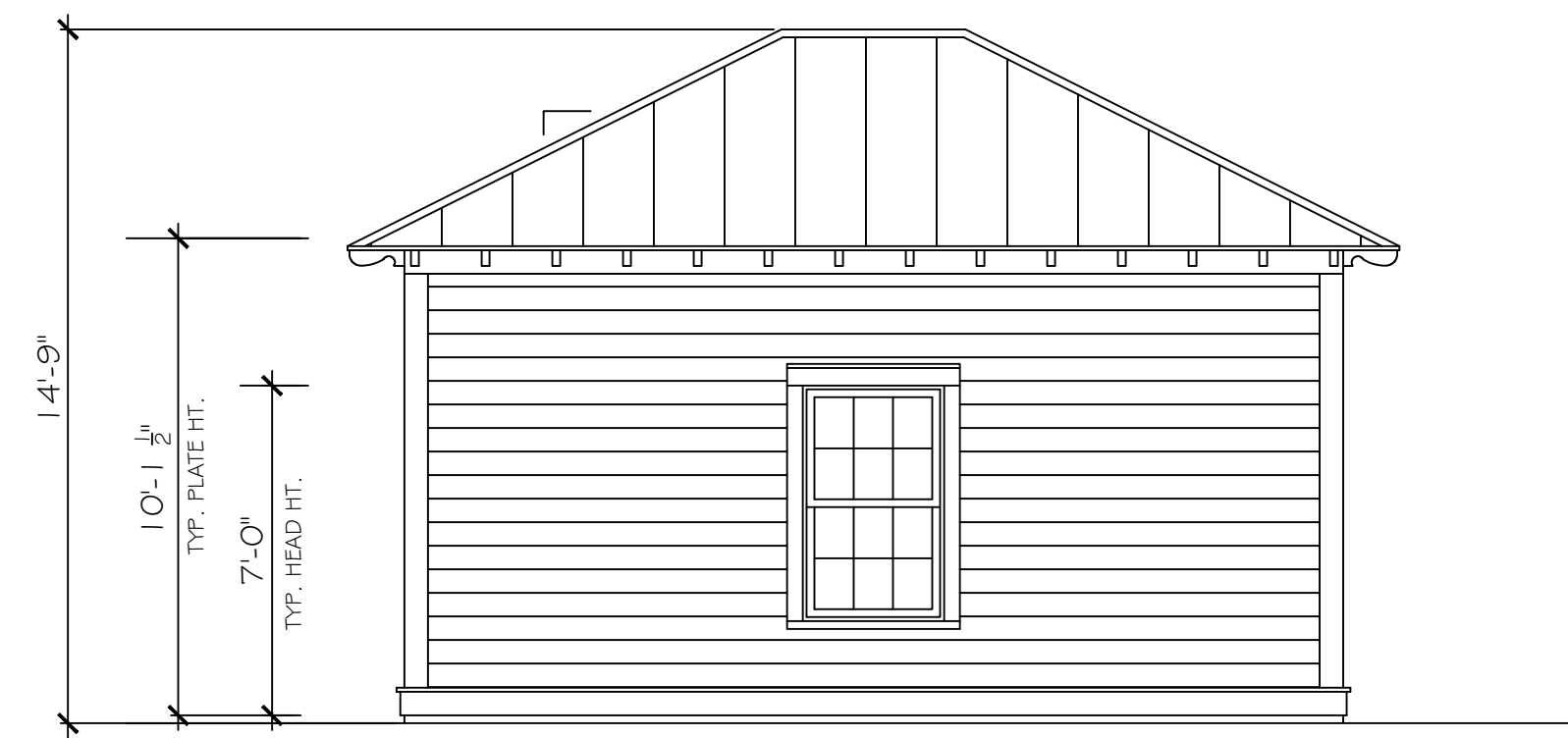

6 LEFT SIDE ELEVATION
SCALE: 1/4" = 1'-0"

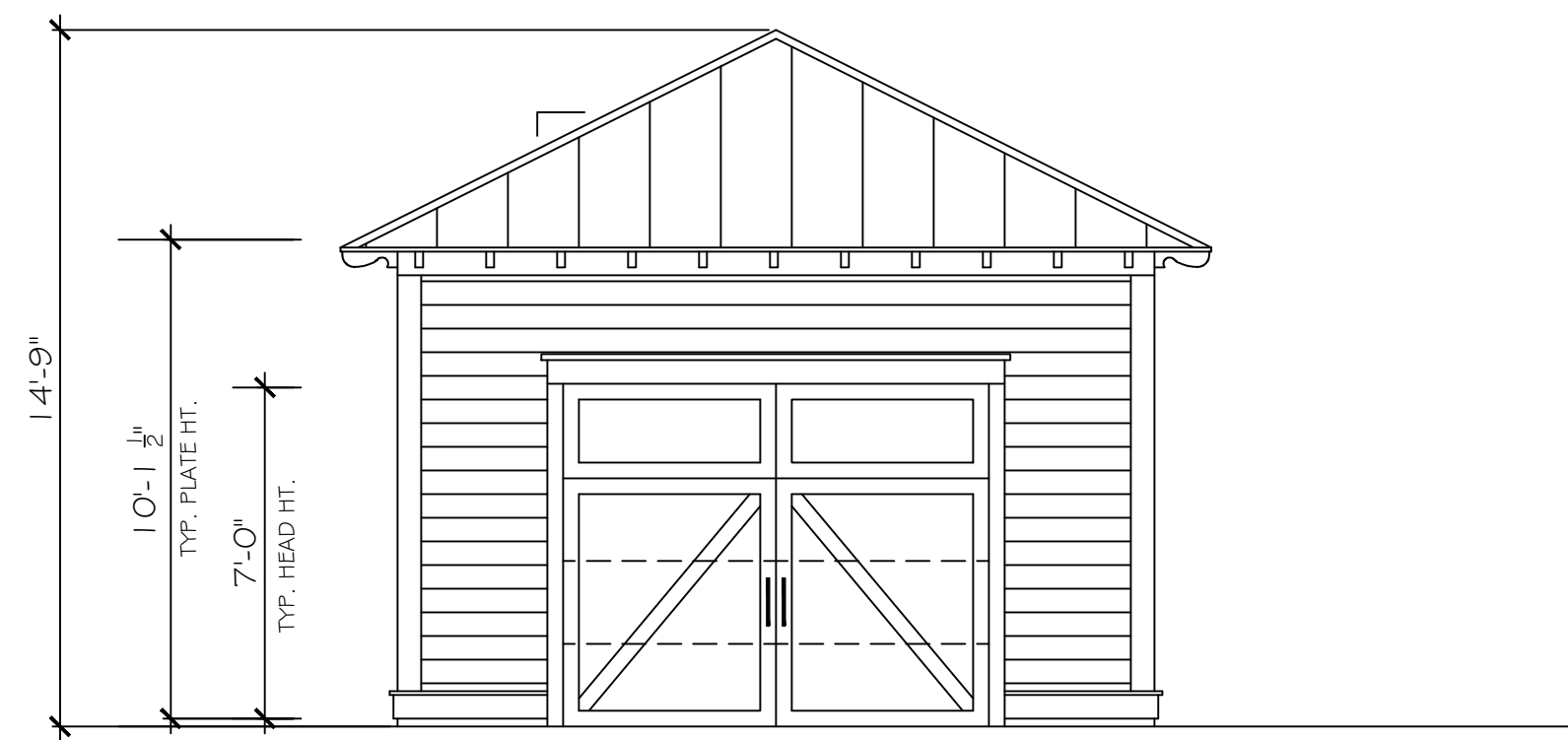

2 FRONT ELEVATION
SCALE: 1/4" = 1'-0"

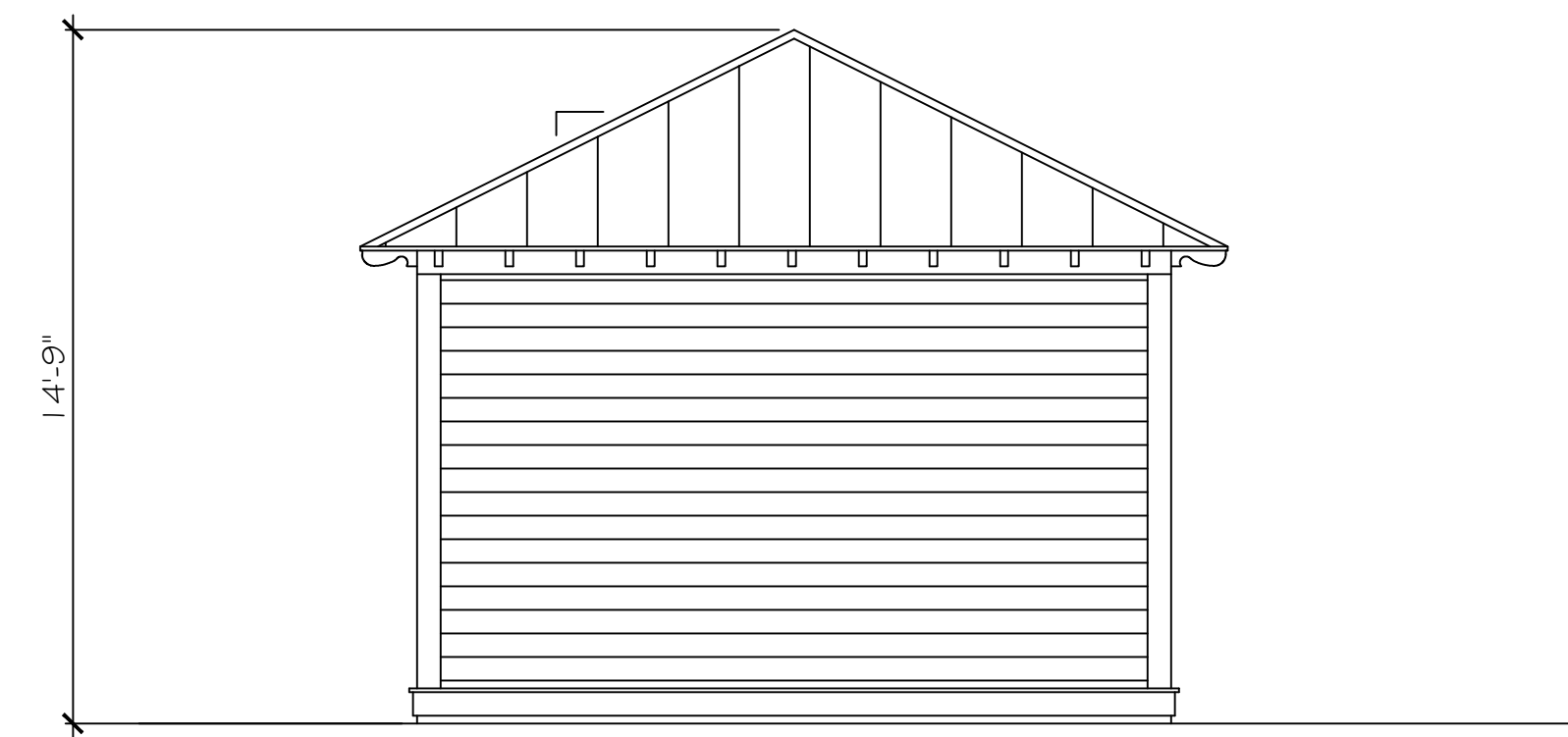

3 REAR ELEVATION
SCALE: 1/4" = 1'-0"

LIGHTING / ELECTRICAL LEGEND:

- 2' OR 4' SINGLE TUBE FLUORESCENT FIXTURE
 - 8' SINGLE TUBE FLUORESCENT FIXTURE
 - 5' RECESSED INCANDESCENT DOWNLIGHTING
 - WALL MOUNTED FIXTURE
 - CEILING MOUNTED FIXTURE
 - WALL SCONCE / GAS LIGHT
 - CEILING MOUNTED FAN
 - PENDANT / CEILING MOUNTED FIXTURE
 - EXHAUST VENT - 100 CFM MIN.
 - SMALL PENDANT
 - DUPLEX OUTLET
 - GROUNDED DUPLEX OUTLET
 - FLOOR OUTLET - OWNER TO LOCATE
 - WEATHER PROOF OUTLET
 - MOTION SENSOR FLOOD
 - MULTI-MEDIA LOCATION (CABLE, SATELLITE, PHONE & DATA)
 - TV, CABLE LOCATION
 - PHONE OUTLET
 - DATA JACK
 - SINGLE PHASE SWITCH
 - THREE WAY SWITCH
 - DIMMER SWITCH
 - SMOKE DETECTOR
- ALL OUTLETS SHALL BE MOUNTED IN THE BASE BOARD

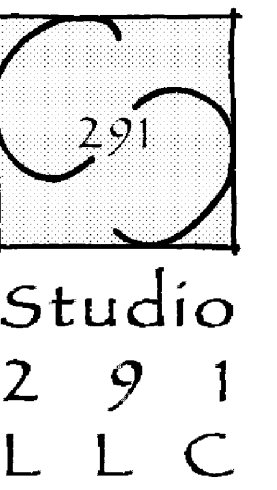

295 Seven Farms Drive
Suite G-174
Charleston, South Carolina 29492
P. (843) 819-8947

This drawing and the design shown is the property of Studio 291, LLC. The reproduction, copying or other use of this drawing without the written consent is prohibited and any infringement will be subject to legal action.

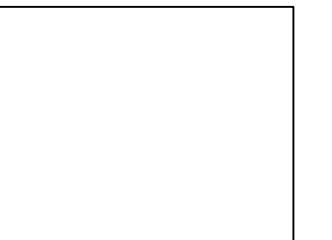
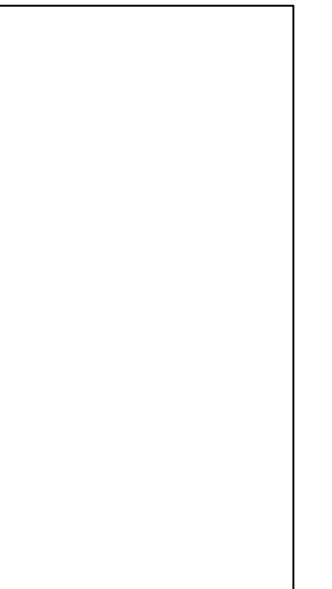

Project
Addition & Renovation @
1754 Central Ave., Sullivan's Island South Carolina
Sheet Title
APPROVED DETACHED GARAGE

D. P. in Charge
J. ADRIAN
Job Captain
J. ADRIAN
Drawn By
JAA
Date Drawn
6/3/23
Issued for Pricing
X
Issued for Permit
8/26/22

Revisions
No. _____ Date _____
No. _____ Date _____
No. _____ Date _____
No. _____ Date _____
No. _____ Date _____
No. _____ Date _____

Issue Date 8/26/22

ISSUED FOR CONSTRUCTION

OWNERS SIGNATURE: _____

CONTRACTORS SIGNATURE: _____

DATE: _____

Project Number

22-291-888

Sheet 12 of 19

A3